

# H60 series

## Outdoor IP67 / IK10 L2 PRO Gigabit PoE Switches



The H60 series of IP67/IK10 L2 PRO Managed PoE Switches are designed with 6KV Ethernet port surge protection, 40KV surge protection in power supply, and harden-graded standard to operate between -40° C and 65° C for harsh weather conditions. They enable outdoor connections of PoE PDs to the network such as outdoor IP cameras, wireless APs, and other outdoor industrial applications.

The H60 series provides multi-port Gigabit PoE (10M/100M/1G) delivering data and power to PoE PDs over a single network cable and additional SFP transceiver slots for flexible uplink. The H60 series has three sub models classified as power source equipment (PSE) and provide PoE budget up to 30W or 90W per port.

Besides general functions of L2 plus & basic L3 switch such as QoS, security, spanning tree, cable length measurement, and SNMP v1/v2c/v3, a dedicated web graphic user interface of IP surveillance is easy to configure and manage ONVIF cameras. It automatically generates camera topology maps, cable diagnostic, and PoE management.

### Features

- Layer 2 Switch
  - 802.1d (STP), 802.1w (RSTP), 802.1s (MSTP)
  - Loop protection
  - SNMP v1/v2c/v3
  - QoS
  - VLAN
  - Ethernet cable length measurement
  - DHCP Server
- Network Topology System
  - Automatic discovery for ONVIF camera
  - Generates camera topology map automatically
  - Cable diagnostic & reboot camera remotely
  - PoE management
  - Topology view / Floor view / Google map
  - Monitor / Configure / Manage ONVIF camera thru web
- Flexible SFP transceiver ports for uplink
- IP67 standard
- IK10 impact rated cast aluminum housing
- Operating temperature between -40°C and 65°C
- Compliant IEEE802.3at 30W per port (H60-044-30-150-V2, H60-084-30-250-V2)
- 90W bt/PoH PoE per port (H60-022-90-120, H60-044-90-250)
- 90W bt PoE per port (H60-044-91-250)
- Supports 10/100/1000Mbps data rates
- 6KV PoE surge protection
- IEEE 802.3az Energy Efficient Ethernet standard for green power

### Applications

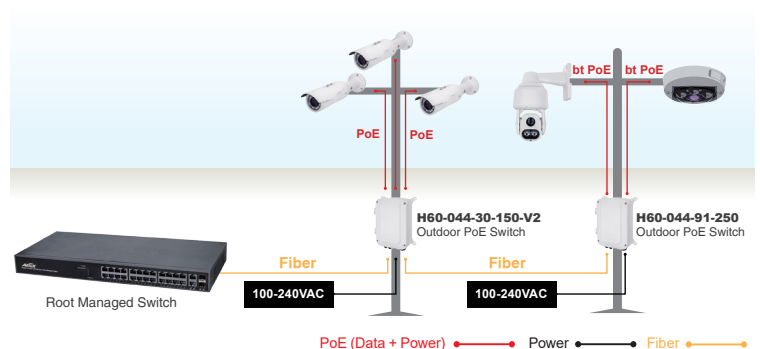
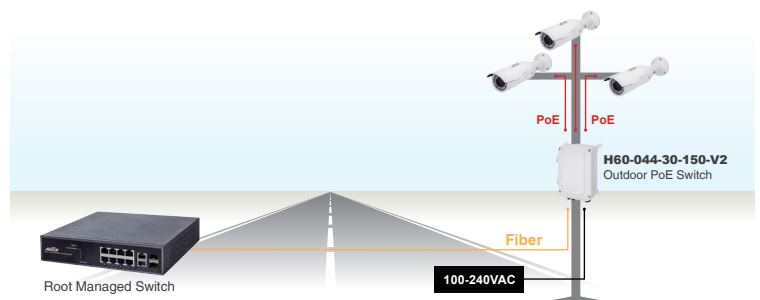

## Device List

Show  entries

Status	Device Type	Model Name	Device Name	MAC	IP Address
Online	PoESW	H60-084-30-250	H60-8p @ 203 name	68:8D:B6:00:CB:00	192.168.10.203
Online	PoESW	H60-084-30-250	H60-8p @ 209 name	68:8D:B6:00:D1:00	192.168.10.209
Online	IPMX	M6000-AIW	M6000-AIW	68:8D:B6:01:E1:B1	192.168.10.165
Online	IP Camera	SNC-VB635	Sony	D8:D4:3C:DD:F5:C7	192.168.10.122
Online	IP Camera	WV-S1131	Panasonic_WV-S1131	BC:C3:42:71:79:D0	192.168.10.104
Online	IPSG	SD-504	SD-504	68:8D:B6:00:00:01	192.168.10.108
Online	PC	General Computer	FC2564	00:50:56:2D:FA:AC	192.168.10.201
Online	Others	Unknown model	Unknown name	04:D4:C4:2C:B5:EC	192.168.10.1
Online	Others	Unknown model	Unknown name	94:C6:91:5F:9E:EA	192.168.10.180
Online	PC	General Computer	MIS-TEMP-NB4	A0:A8:CD:26:FE:FD	192.168.10.192

Showing 1 to 10 of 29 entries

Previous  2 3 Next

[Edit](#)

## Topology View

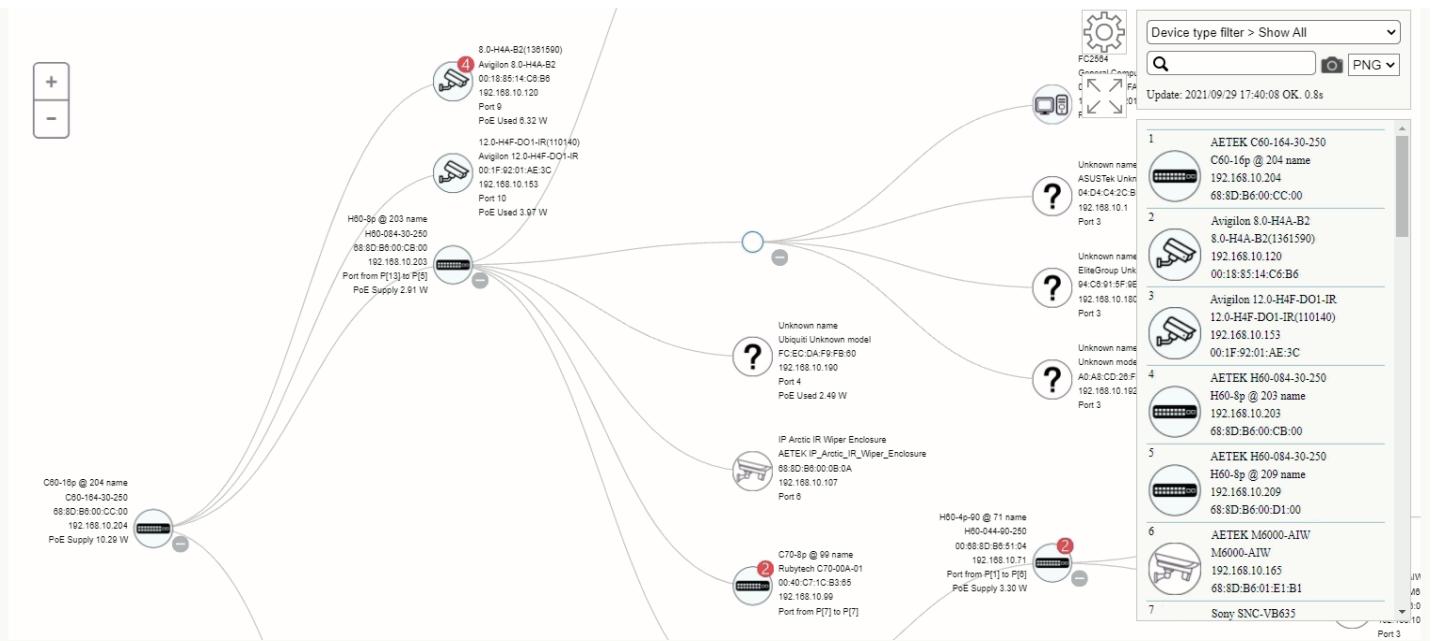

## Device Dashboard

The device dashboard for the IP camera (Avigilon 12.0-H4F-DO1-IR) displays the following information:

- Device Type:** IP Cameras
- Device Name:** 12.0-H4F-DO1-IR(110140)
- Model Name:** 12.0-H4F-DO1-IR
- MAC Address:** 00:1F:92:01:AE:3C
- IP Address:** 192.168.10.153
- Http Port:** 80
- PoE Used:** 4.21 W

Management options include Login, Diagnostics, and PoE Reboot. The dashboard also features a navigation bar with Dashboard, Notification, and Monitor tabs.

## Floor Map View

**Device Dashboard**

Device Type: PoE Switches

Device Name: H60-4p-90 @ 73 name

Model Name: H60-044-90-250

MAC Address: 00:E0:4C:51:04:0A

IP Address: 192.168.10.73

Http Port: 80

PoE Supply: 0 W

API Account: admin73

API Password: passwd73

Buttons: Close, Apply

Icons: Login, Upgrade, PoE Config, Diagnostics

Bottom: Dashboard, Notification

**Device List:**

- 1 AETEK C60-164-30-250 C60-16p @ 204 name 192.168.10.204 68:8D:B6:00:CC:00
- 2 Avigilon 8.0-H4A-B2 8.0-H4A-B2(1361590) 192.168.10.120 00:18:85:14:C6:B6
- 3 Avigilon 12.0-H4F-DO1-IR 12.0-H4F-DO1-IR(110140) 192.168.10.153 00:1F:92:01:AE:3C
- 4 AETEK H60-084-30-250 H60-8p @ 203 name 192.168.10.203 68:8D:B6:00:CB:00
- 5 AETEK H60-084-30-250 H60-8p @ 209 name 192.168.10.209 68:8D:B6:00:D1:00
- 6 AETEK M6000-AIW M6000-AIW 192.168.10.165

Update: 2021/09/29 17:44:22 OK. 0.7s

## Google Map View

**Device Dashboard**

Device Type: PoE Switches

Device Name: H60-8p @ 203 name

Model Name: H60-084-30-250

MAC Address: 68:8D:B6:00:CB:00

IP Address: 192.168.10.203

Http Port: 80

PoE Supply: 2.54 W

API Account: admin203

API Password: passwd203

Buttons: Close, Apply

Icons: Upgrade, PoE Config

Bottom: Dashboard, Notification

**Device List:**

- 1 AETEK C60-164-30-250 C60-16p @ 204 name 192.168.10.204 68:8D:B6:00:CC:00
- 2 Avigilon 8.0-H4A-B2 8.0-H4A-B2(1361590) 192.168.10.120 00:18:85:14:C6:B6
- 3 Avigilon 12.0-H4F-DO1-IR 12.0-H4F-DO1-IR(110140) 192.168.10.153 00:1F:92:01:AE:3C
- 4 AETEK H60-084-30-250 H60-8p @ 203 name 192.168.10.203 68:8D:B6:00:CB:00
- 5 AETEK H60-084-30-250 H60-8p @ 209 name 192.168.10.209 68:8D:B6:00:D1:00
- 6 AETEK M6000-AIW M6000-AIW 192.168.10.165

Update: 2021/09/29 17:48:45 OK. 1.4s

Buttons: Draggable: ONE, Animation: OFF

## Cable Diagnostics

**Diagnostics**

Device Type: IP Cameras

Device Name: 12.0-H4F-DO1-IR(110140)

Model Name: 12.0-H4F-DO1-IR

MAC Address: 00:1F:92:01:AE:3C

IP Address: 192.168.10.153

**Icon Diagnostic**

- 1 AETEK C60-164-30-250 C60-16p @ 204 name 192.168.10.204 68:8D:B6:00:CC:00
  - Port: 10 ✓ Connection ok
  - Speed: 100M ✓ Cable Status ok
- 3 Avigilon 12.0-H4F-DO1-IR 12.0-H4F-DO1-IR(110140) 192.168.10.153 00:1F:92:01:AE:3C

← Back

**Device List:**

- 1 AETEK C60-164-30-250 C60-16p @ 204 name 192.168.10.204 68:8D:B6:00:CC:00
- 2 Avigilon 8.0-H4A-B2 8.0-H4A-B2(1361590) 192.168.10.120 00:18:85:14:C6:B6
- 3 Avigilon 12.0-H4F-DO1-IR 12.0-H4F-DO1-IR(110140) 192.168.10.153 00:1F:92:01:AE:3C
- 4 AETEK H60-084-30-250 H60-8p @ 203 name 192.168.10.203 68:8D:B6:00:CB:00
- 5 AETEK H60-084-30-250 H60-8p @ 209 name 192.168.10.209 68:8D:B6:00:D1:00
- 6 AETEK M6000-AIW M6000-AIW 192.168.10.165
- 7 Sony SNC-VB635

Update: 2021/09/29 17:48:48 OK. 0.7s

Buttons: PNG

## PoE Features

- IEEE802.3at (PoE+ 30W),bt 90W
- Max. allowed 30W / 90W per port
- Port status table

PoE Port Configuration						
Local Port	PD Class	Power Used	Current Used	Priority	Port Status	
1	-	0.00 [W]	0 [mA]	high	No PD detected	
2	-	0.00 [W]	0 [mA]	high	No PD detected	
3	-	0.00 [W]	0 [mA]	high	No PD detected	
4	class0	2.65 [W]	50 [mA]	high	on	
5	-	0.00 [W]	0 [mA]	high	No PD detected	
6	-	0.00 [W]	0 [mA]	high	No PD detected	
7	-	0.00 [W]	0 [mA]	high	No PD detected	
8	-	0.00 [W]	0 [mA]	high	No PD detected	
Total		2.00 [W]				

## Specifications - Software

PoE Management	
Port Configuration	Supports per port PoE configuration function
PoE Scheduling	Supports per port PoE scheduling to turn on/off the PoE devices (PDs).
Auto-checking	Check the link status of PDs. Reboot PDs if there is no responses
Power Delay	The switch provides power to the PDs based on delay time when PoE switch boots up, in order to protect switch from misuse of the PDs.
IP Surveillance Graphical User Interface Specifications	
Automatic Discovery	Discover IP cameras complying ONVIF automatically
Topology View	Generate Topology maps to manage IP cameras
Floor view	It's easy to drag and drop PoE devices and help you to build smart workforces
Map view	Enhance efficiency to drag and drop devices and monitor surroundings on google map
Traffic Monitoring	Comprehensive chart to show traffic status
PoE Management	Reboot IP camera, Scheduling PoE on/off, alive checking, Power delay as PoE switch boots up, PoE configuration
Layer 2 Switching Specifications	
Spanning Tree Protocol	MAC Bridges Standard Spanning Tree (STP) 802.1d, Rapid Spanning Tree (RSTP) 802.1w, Multiple Spanning Tree (MSTP) 802.1s
IP/Mac Port Trunking	Link Aggregation Control Protocol (LACP) IEEE 802.3ad , Static aggregation.
VLAN	Supports up to 4K VLANs simultaneously (out of 4096 VLAN IDs), Port-based VLAN, 802.1Q tag-based VLAN
IGMP v1/v2 Snooping	IGMP limits bandwidth-intensive multicast traffic to only the requesters.
Layer 3 Switching Specifications	
DHCP Server	Assign IP to DHCP clients
Security	
IEEE 802.1X	IEEE802.1X: RADIUS authentication, authorization and accounting, MD5 hash, guest VLAN, single/multiple host mode and single/multiple sessions, Supports IGMP-RADIUS based 802.1X, Dynamic VLAN assignment
Port Security	Locks MAC addresses to ports, and limits the number of learned MAC address
Storm Control	Prevents traffic on a LAN from being disrupted by a broadcast, multicast, or unicast storm on a port
Loop Protection	To prevent unknown unicast, broadcast and multicast loops in Layer 2 switching configurations.
RADIUS/ TACACS+	Supports RADIUS and TACACS+ authentication. Switch as a client
QoS	
Classification	Port based, 802.1p VLAN priority based
Bandwidth Control	Ingress policer, Egress shaping and rate control, Per port
Management software	
Port Mirroring	Traffic on a port can be mirrored to another port for analysis with a network analyzer or RMON probe. Up to N-1 (N is Switch's Ports) ports can be mirrored to single destination port. A single session is supported.
IEEE 802.1ab (LLDP)	Used by network devices for advertising their identities, capabilities, and neighbors on an IEEE 802ab local area network, Support LLDP-MED extensions
Web GUI Interface	Built-in switch configuration utility for browser-based device configuration
SNMP	SNMP version1, 2c, 3
Flow Control	The IEEE 802.3x standard for monitoring high speed switched networks. It gives complete visibility into the use of networks enabling performance optimization, accounting/billing for usage, and defense against security threats
Firmware Upgrade	Web browser upgrade HTTP and TFTP
NTP	Network Time Protocol (NTP) is a networking protocol for clock synchronization between computer systems over packet-switched
Other Management	System, HTTP, DHCP Client, Cable Diagnostics, Syslog, IPV4/IPV6 Management, SSH, Telnet

## Specifications

	H60-022-90-120	H60-044-30-150-V2	H60-044-90-250
<b>Software function: NTS(Monitoring and management of surveillance)</b>			
NTS Edge	support	support	support
NTS Server	support	support	support
<b>Networking</b>			
Total Gigabit Ethernet Ports	4	8	8
Gigabit Ethernet 802.3af/at PoE Ports	--	4	--
Gigabit Ethernet 802.3af/at/bt/PoH PoE Ports	2	--	4
Gigabit Ethernet RJ45 Ports	--	2	2
Gigabit Ethernet SFP Ports (100M/1G)	2	2	2
Forwarding Capacity	5.952Mpps	11.904Mpps	11.904Mpps
Mac Table	8K	8K	8K
Jumbo Frames	9,216 Bytes	9,216 Bytes	9,216 Bytes
Switching Capacity	8 Gbps	16 Gbps	16 Gbps
<b>Power</b>			
Input Power	100~240V AC and 48-56V DC Backup Input Power	100~240V AC and 48-56V DC Backup Input Power	100~240V AC and 48-56V DC Backup Input Power
ESD	Contact ±6 KV, Air ±8 KV	Contact ±6 KV, Air ±8 KV	Contact ±6 KV, Air ±8 KV
Redundant Mode	AC Primary / DC Secondary	AC Primary / DC Secondary	AC Primary / DC Secondary
Output Power per PoE Port	PoE IEEE 802.3af (Max. 15.4W) PoE+ IEEE 802.3at (Max. 30W) PoE++ IEEE 802.3bt/PoH (Max. 90W)	PoE IEEE 802.3af (Max. 15.4W) PoE+ IEEE 802.3at (Max. 30W)	PoE IEEE 802.3af (Max. 15.4W) PoE+ IEEE 802.3at (Max. 30W) PoE++ IEEE 802.3bt/PoH (Max. 90W)
Output PoE Power Pin Assignment	12(-), 36(+), 45(+), 78(-)	12(+), 36(-)	12(-), 36(+), 45(+), 78(-)
Standby Power Consumption	110V AC: 8W 240V AC: 7.5W	110V AC: 11W 240V AC: 10.2W	110V AC: 10.3W 240V AC: 10W
PoE Output Power Budget	120W	120W	240W
Power Supply	150W	150W	250W
Surge Protection per PoE Port	Common mode : ±6 KV	Common mode : ±6 KV	Common mode : ±6 KV
Surge Protection for AC Power Input	10KV	40KV	40KV
<b>Mechanical</b>			
Dimensions (W x D x H)	199.88 x 255.22 x 90 mm (7.9 x 10.0 x 3.5 in)	245.8 x 315.4 x 118 mm (9.7 x 12.4 x 4.6 in)	245.8 x 315.4 x 118 mm (9.7 x 12.4 x 4.6 in)
Weight	3.2 kg (7.05 lb)	4.2 kg (9.26 lb)	4.3 kg (9.48 lb)
DI	-	Dry Contact: Logic level 1: Close to GND Logic level 0: Open	Wet Contact: Logic level 1 : 5~12 Volts (10mA) Logic level 0 : 0~1 Volts
DO	-	24V DC/1A (Max)	24V DC/1A (Max)
Console	RJ45	RJ45	RJ45
Cooling Fan	Fanless	Fanless	Fanless
<b>Environmental limits</b>			
IP Rating / IK Rating	IP67 / IK10	IP67 / IK10	IP67 / IK10
Operating Temperature	-40°C ~ 65°C (-40°F ~ 149°F)	-40°C ~ 65°C (-40°F ~ 149°F)	-40°C ~ 65°C (-40°F ~ 149°F)
Storage Temperature	-40°C ~ 85°C (-40°F ~ 185°F)	-40°C ~ 85°C (-40°F ~ 185°F)	-40°C ~ 85°C (-40°F ~ 185°F)
Operating Humidity	5% ~ 95% non-condensing	5% ~ 95% non-condensing	5% ~ 95% non-condensing
<b>Regulatory/ Approvals</b>			
EMC	CE, FCC, VCCI, C-Tick	CE, FCC, VCCI, C-Tick	CE, FCC, VCCI, C-Tick
Safety	EN62368-1	EN62368-1	EN62368-1
Surge	EN61000-4-5	EN61000-4-5	EN61000-4-5
MTBF	>50000 hours	>50000 hours	>50000 hours
<b>Optional Accessories</b>			
Fiber Splice Tray	AT-302	AT-303-V2	AT-303-V2
Mounting Brackets	AT-100 / AT-101 / AT-200		
SFP Module	SFP Module Model Table		
Side Opening Alarm Switch Kit	BK-404	BK-402	BK-402

# Specifications

	H60-044-91-250	H60-084-30-250-V2
<b>Software function: NTS(Monitoring and management of surveillance)</b>		
NTS Edge	support	support
NTS Server	support	support
<b>Networking</b>		
Total Gigabit Ethernet Ports	8	12
Gigabit Ethernet 802.3af/at PoE Ports	--	8
Gigabit Ethernet 802.3af/at/bt PoE Ports	4	--
Gigabit Ethernet RJ45 Ports	2	--
Gigabit Ethernet SFP Ports (100M/1G)	2	4
Forwarding Capacity	11.904Mpps	17.856Mpps
Mac Table	8K	8K
Jumbo Frames	9,216 Bytes	9,216 Bytes
Switching Capacity	16 Gbps	24 Gbps
<b>Power</b>		
Input Power	100~240V AC and 48-56V DC Backup Input Power	100~240V AC and 48-56V DC Backup Input Power
ESD	Contact ±6 KV, Air ±8 KV	Contact ±6 KV, Air ±8 KV
Redundant Mode	AC Primary / DC Secondary	AC Primary / DC Secondary
Output Power per PoE Port	PoE IEEE 802.3af (Max. 15.4W) PoE+ IEEE 802.3at (Max. 30W) PoE++ IEEE 802.3bt (Max. 90W)	PoE IEEE 802.3af (Max. 15.4W) PoE+ IEEE 802.3at (Max. 30W)
Output PoE Power Pin Assignment	12(-), 36(+), 45(+), 78(-)	12(+), 36(-)
Standby Power Consumption	110V AC: 10.3W 240V AC: 10W	110V AC: 11.5W 240V AC: 11W
PoE Output Power Budget	240W	240W
Power Supply	250W	250W
Surge Protection per PoE Port	Common mode : ±6 KV	Common mode : ±6 KV
Surge Protection for AC Power Input	40KV	40KV
<b>Mechanical</b>		
Dimensions (W x D x H)	245.8 x 315.4 x 118 mm (9.7 x 12.4 x 4.6 in)	245.8 x 315.4 x 118 mm (9.7 x 12.4 x 4.6 in)
Weight	4.3 kg (9.48 lb)	4.37 kg (9.63 lb)
Connectors	PF 3/4 x1 M25 cable gland with 5x5mm holes x1 M16 cable gland with x6.5mm hole x4	PF 3/4 x1 M25 cable gland with 5x5mm holes x1 M16 cable gland with x6.5mm hole x4
DI	Wet Contact: Logic level 1 : 5~12 Volts (10mA) Logic level 0 : 0~1 Volts	Dry Contact: Logic level 1: Close to GND Logic level 0: Open
DO	24V DC/1A (Max)	24V DC/1A (Max)
Console	RJ45	RJ45
Cooling Fan	Fanless	Fanless
<b>Environmental limits</b>		
IP Rating / IK Rating	IP67 / IK10	IP67 / IK10
Operating Temperature	-40°C ~ 65°C (-40°F ~ 149°F)	-40°C ~ 65°C (-40°F ~ 149°F)
Storage Temperature	-40°C ~ 85°C (-40°F ~ 185°F)	-40°C ~ 85°C (-40°F ~ 185°F)
Operating Humidity	5% ~ 95% non-condensing	5% ~ 95% non-condensing
<b>Regulatory/ Approvals</b>		
EMC	CE, FCC, VCCI, C-Tick	CE, FCC, VCCI, C-Tick
Safety	EN62368-1	EN62368-1
Surge	EN61000-4-5	EN61000-4-5
MTBF	>50000 hours	>50000 hours
<b>Optional Accessories</b>		
Fiber Splice Tray	AT-303-V2	AT-303-V2
Mounting Brackets	AT-100 / AT-101 / AT-200	
SFP Module	SFP Module Model Table	
Side Opening Alarm Switch Kit	BK-402	BK-402

## Dimension

- H60-044-30-150-V2 / H60-044-90-250 / H60-044-91-250 / H60-084-30-250-V2

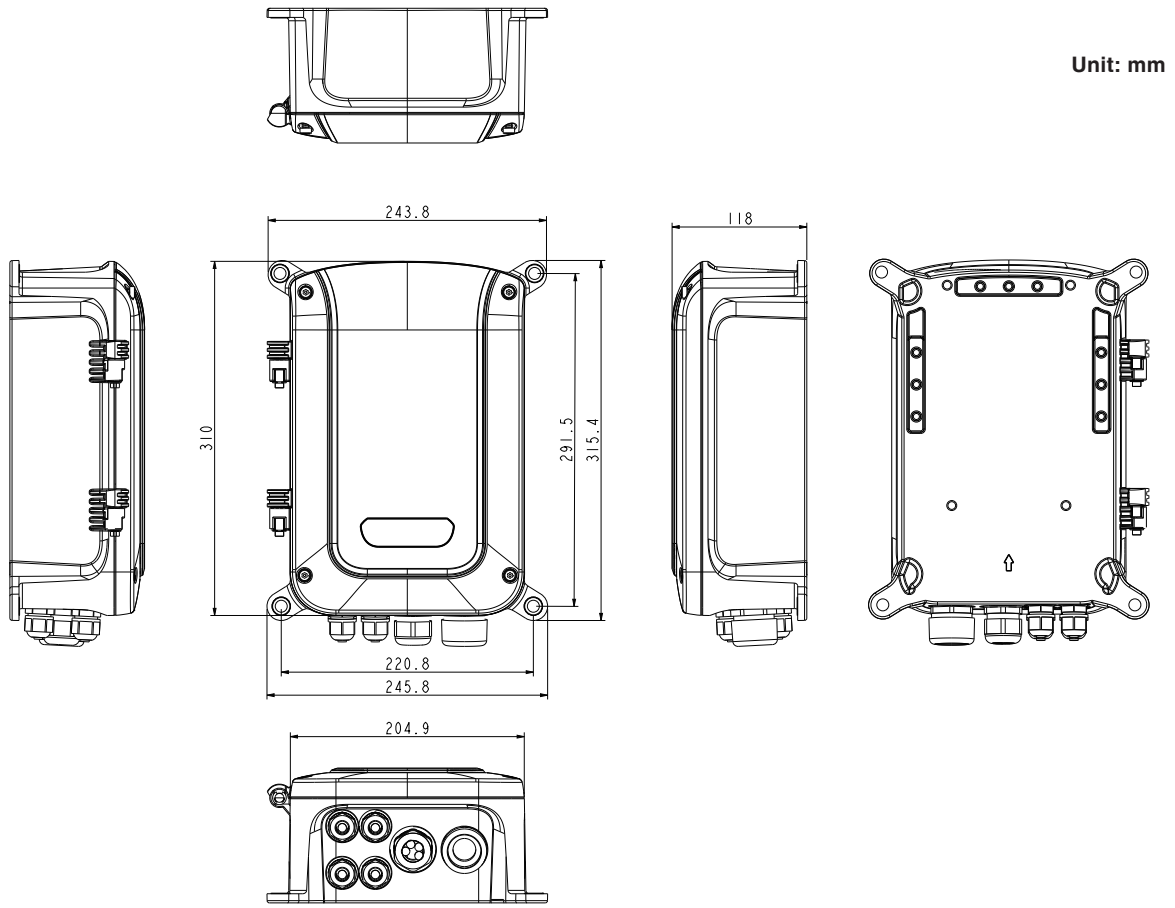

- H60-022-90-120

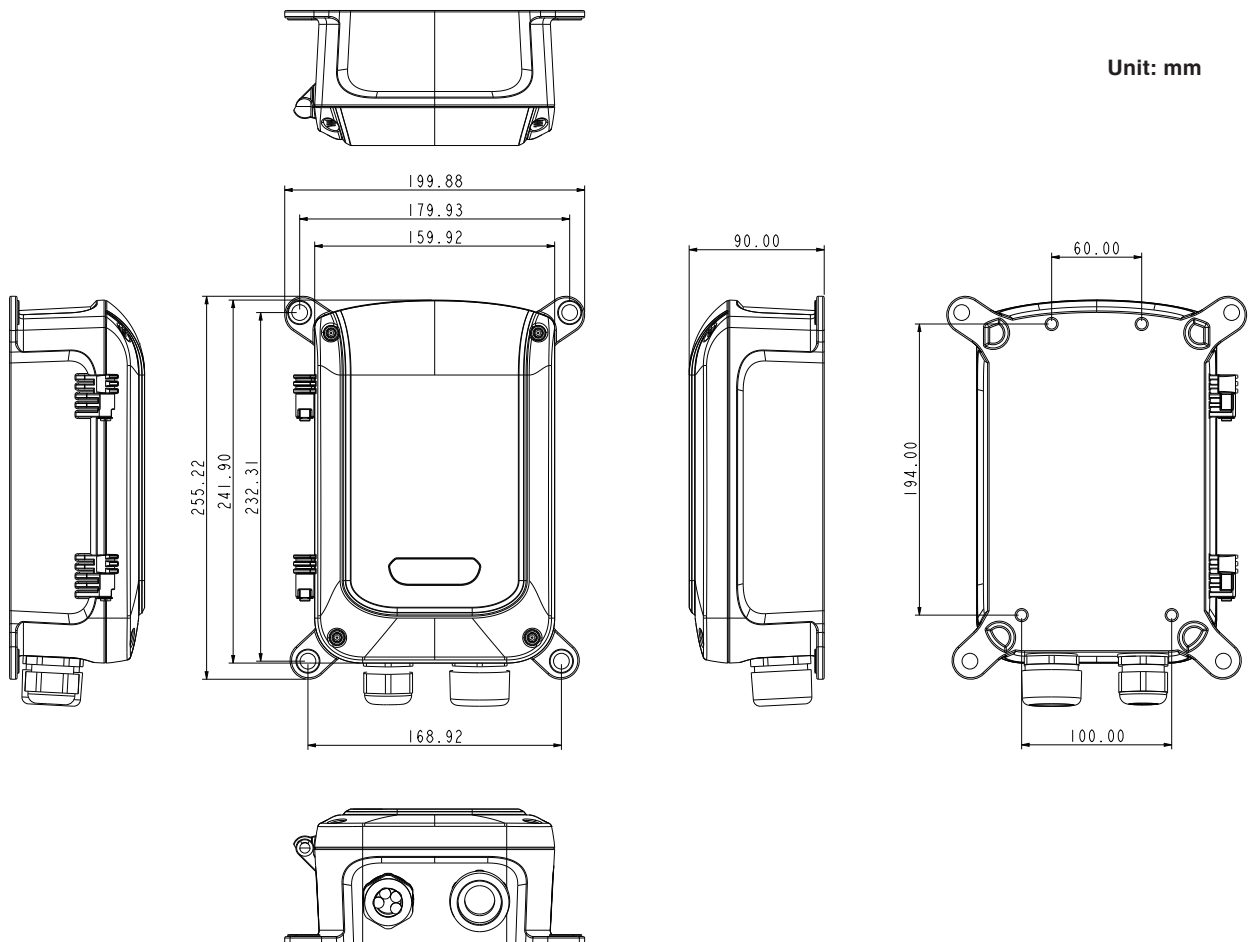

## Ordering Information

### PoE Switches

#### • H60-022-90-120

- 2xGbE bt / PoH PoE (90W)
- + 2xGbE SFP
- 100~240VAC, 120W power budget



#### H60-044-30-150-V2

- 4xGbE at PoE (30W)
- + 2xGbE SFP
- + 2xGbE RJ45
- 100~240VAC, 120W power budget



#### H60-044-90-250

- 4xGbE bt / PoH PoE (90W)
- + 2xGbE SFP
- + 2xGbE RJ45
- 100~240VAC, 240W power budget



### PoE Switches

#### H60-044-91-250

- 4xGbE bt PoE (90W)
- + 2xGbE SFP
- + 2xGbE RJ45
- 100~240VAC, 240W power budget



#### H60-084-30-250-V2

- 8xGbE at PoE (30W)
- + 4xGbE SFP
- 100~240VAC, 240W power budget



## Optional Accessories

### SFP Modules



#### SFP-ISX-X5

Industrial Gigabit SFP Transceiver

- MMF
- 0.5 km
- -40°C ~85°C



#### SFP-ISX-02

Industrial Gigabit SFP Transceiver

- MMF
- 2 km
- -40°C ~85°C



#### SFP-ILX-10

Industrial Gigabit SFP Transceiver

- SMF
- 10 km
- -40°C ~85°C



#### SFP-ILX-40

Industrial Gigabit SFP Transceiver

- SMF
- 40 km
- -40°C ~85°C

### Pole Mount Brackets



#### AT-100

Pole Mount Adapter



#### AT-101

Pole Mount Adapter

### Corner Mount Bracket

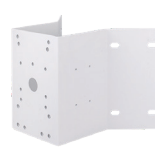

#### AT-200

Corner Mount Adapter

### Fiber Splice Tray



#### AT-302

Fiber Splice Tray



#### AT-303-V2

Fiber Splice Tray